

PRORIL

50Hz

Designed for continuous operations, excellent performance and easy maintenance, PRORIL Tank series pumps have proven their reliability and durability in demanding areas like construction, mining, tunneling, quarries, industries and rental applications.

Dewatering Pump

TANK 4150/6150

High Chrome Dewatering Pump



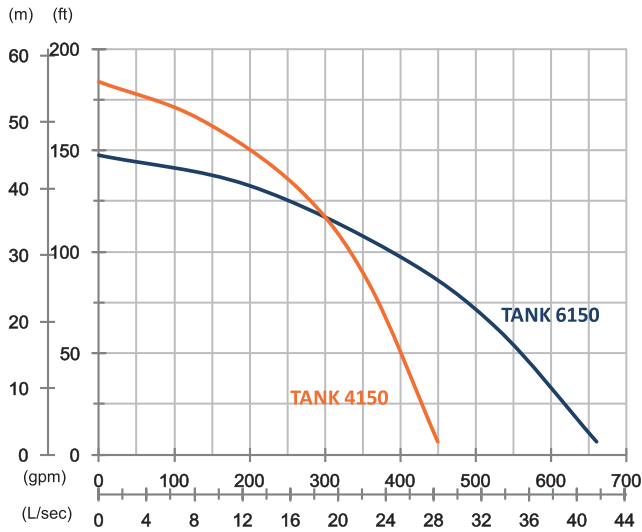

	TANK 4150	TANK 6150
OUTPUT	15 kW (20 HP)	15 kW (20 HP)
OUTLET	4" (100 mm)	6" (150 mm)
SOLID PASSAGE	15 mm	15 mm
Weight	141 kg	142 kg
HEAD	Rated: 40 m Max: 56 m	Rated: 30 m Max: 45 m
FLOW	Rated: 16.7 L/s Max: 28.3 L/s	Rated: 25 L/s Max: 41.6 L/s

Pump Type		Electric Submersible Pumps
Motor	Phase	3-Phase
	Type	Induction Motor
	Poles	2 Pole (2850 rpm)
	Insulation	Class F
	Protector	Circle Thermal Protector
Starter		D.O.L.
Lubricant		Food Grade (ISO VG32)
Specs.	Impeller Type	Opened
	Shaft Seal	Double Mechanical Seal
		Silicon Carbide VS Ceramic Carbon
	Bearings	C3 Shielded ball bearings
	Cable	H07BQ-F
10 m or longer upon request		
Materials	Pump Casing	Gray Iron
	Impeller	Chromium Iron
	Motor Frame	Gray Iron
	Motor Shaft	Stainless Steel
	Strainer	Stainless Steel
Max. Liquid Temperature		40°C (104°F)
Max. Submersion Depth		20 m (66 ft)
pH Range		pH 5 - pH 8

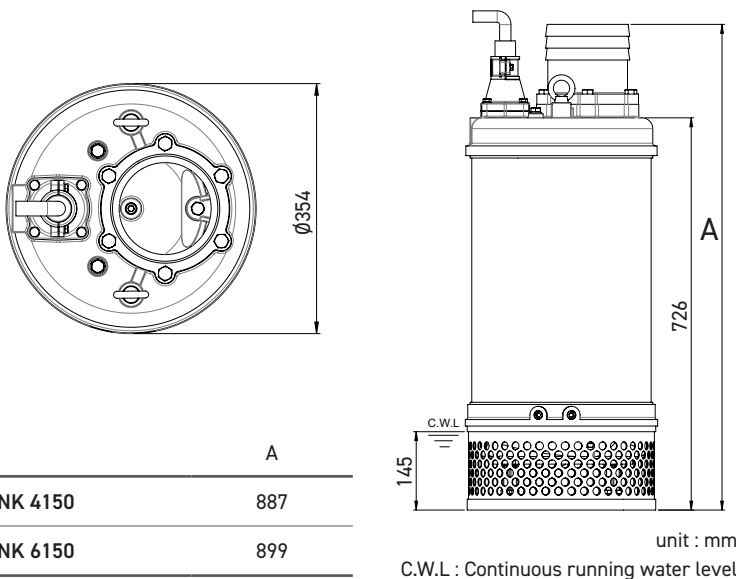

	A
TANK 4150	887
TANK 6150	899